



ORBITAL HYDRAULIC MOTOR

MODEL BM3Y



WWW.OLEODINAMICAMOZIONI.IT



BM3Y INTRODUCTION

THIS SERIES OF MOTOR, WITH ITS SHELL MADE OF DUCTILE CAST IRON OF ADEQUATE INTENSITY, CAN BE APPLIED TO SITUATIONS WITH LESS LOAD AND INTERVAL OPERATION, WIDELY TO AGRICULTURE, FORESTRY, PLASTICS, MACHINE TOOLS AND MINI MACHINES, SUCH AS THE MOLD HEIGHT ADJUSTMENT OF THE INJECTION MOLDING MACHINE, THE CLEANER, THE SAWMILL THE WORKTABLE ETC.



BM3Y TECHNICAL DATA

TYPE		BM3Y-80 BM3WY-80	BM3Y-100 BM3WY-100	BM3Y-125 BM3WY-125	BM3Y-160 BM3WY-160	BM3Y-200 BM3WY-200	BM3Y-250 BM3WY-250	BM3Y-315 BM3WY-315	BM3Y-400 BM3WY-400	BM3Y-500 BM3WY-500
DISPLACEMENT (CM ³ /R)		80.5	100.5	126.3	160.8	200.9	252.6	321.5	401.9	476.5
MAX. PRESSURE, DROP (MPA)	CONT.	20.5	20.5	20.5	20.5	20.5	20	20	15.5	12
	INT.	27.9	27.9	27.9	26	25	25	24	19	14
	PEAK.	29.5	29.5	29.5	28	27	27	26	21	16
MAX. TORQUE (N·M)	CONT.	226	282	355	451	564	684	870	813	728
	INT.	293	365	459	559	672	845	1032	1021	903
	PEAK.	306	383	481	588	708	891	1091	1141	1044
MAX. SPEED (R/MIN)		805	745	590	465	370	295	230	185	155
MAX. FLOW (CONT.) (L/MIN)		65	75	75	75	75	75	75	75	75
MAX. OUTPUT, POWER (CONT.) (KW)		16	18	18	18	18	18	17	11	9
WEIGHT (KG)		9.8	10.0	10.3	10.7	11.1	11.6	12.3	13.2	14.3

INTERMITTENT OPERATION THE PERMISSIBLE VALUES MAY OCCUR FOR MAX. 10% OF EVERY MINUTE
PEAK LOAD: THE PERMISSIBLE VALUES MAY OCCUR FOR MAX. 1% OF EVERY MINUTE



BM3Y INSTALLATION

TYPE	BM3Y-80	BM3Y-100	BM3Y-125	BM3Y-160	BM3Y-200	BM3Y-250	BM3Y-315	BM3Y-400	BM3Y-500
L	170	170	178	184	191	200	212	226	239
L1	125.5	129	133.5	139.5	146.5	155.5	167.5	181.5	194.5
B	11	14.5	19	25	32	41	53	67	80

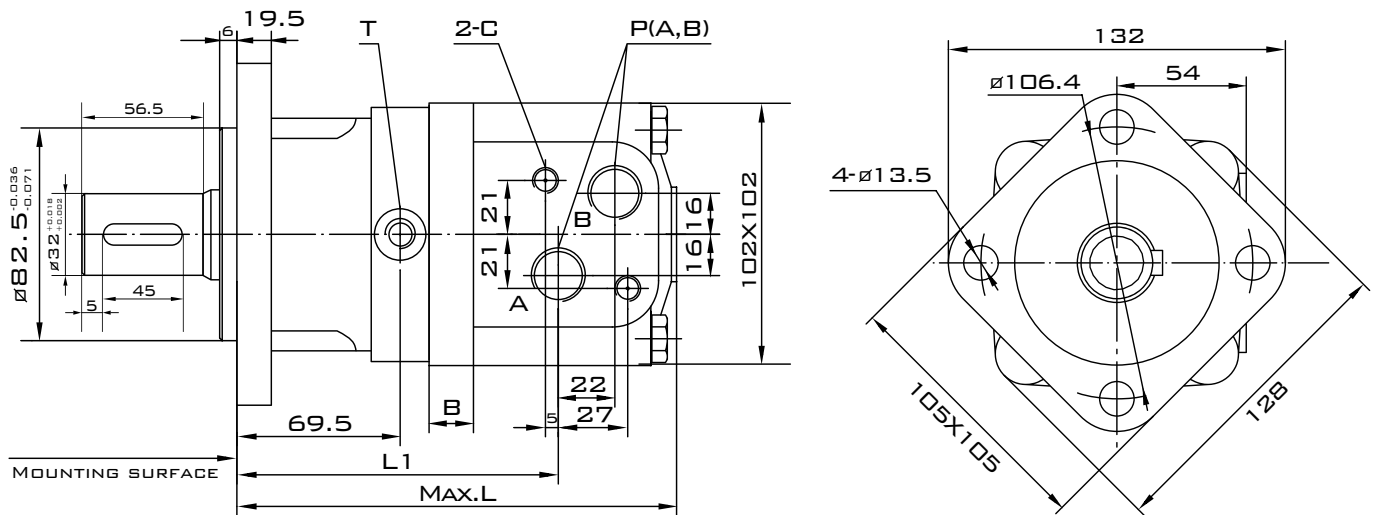

SQUARE FLANGE A

BM3Y PORTS CODE

CODE	PORTS	P(A,B)(DEEP)	C(DEEP)	T (DEEP)
Y		G 1/2 (15)	M10 (12)	G 1/4 (12)

BM3WY INSTALLATION

TYPE	BM3WY-80	BM3WY-100	BM3WY-125	BM3WY-160	BM3WY-200	BM3WY-250	BM3WY-315	BM3WY-400	BM3WY-500
L	127.5	131	135.5	141.5	148.5	157.5	169.5	183.5	196.5
L1	83	86.5	91	97	104	113	125	139	152
B	11	14.5	19	25	32	41	53	67	80

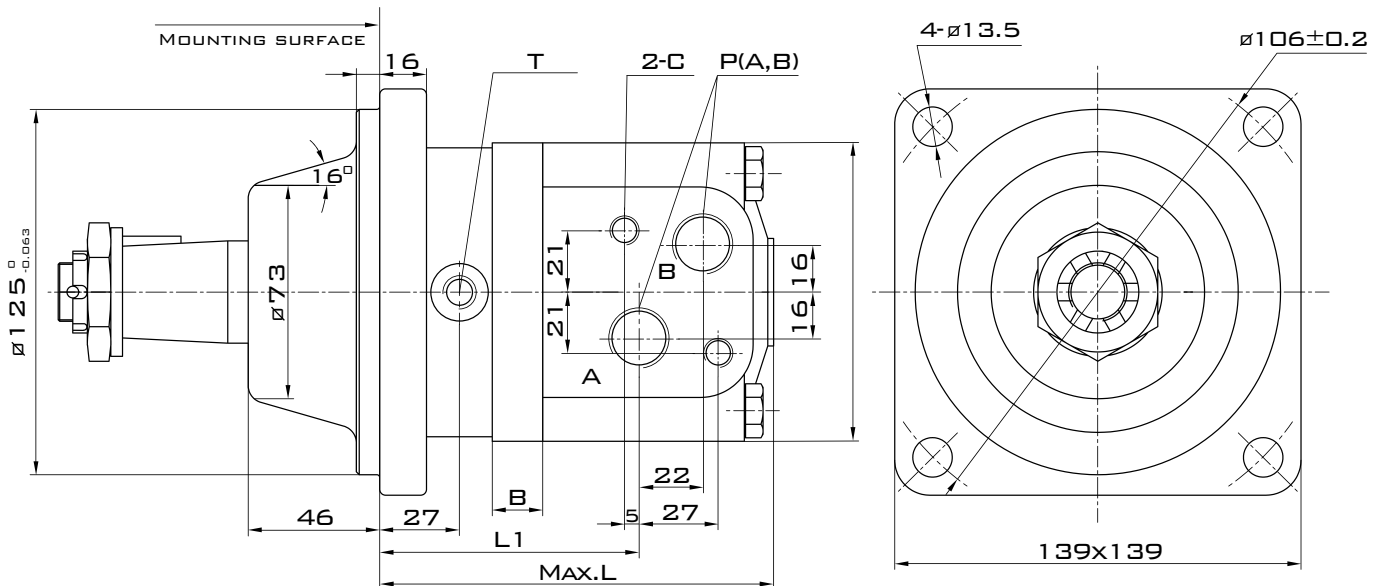

BM3WY PORTS CODE

CODE	PORTS	P(A,B)(DEEP)	C(DEEP)	T (DEEP)
Y		G 1/2 (15)	M 10 (12)	G 1/4 (12)



SHAFT VERSION

P10: $\varnothing 32$ CYLINDRICAL SHAFT,
PARALLEL KEY 10X8X45

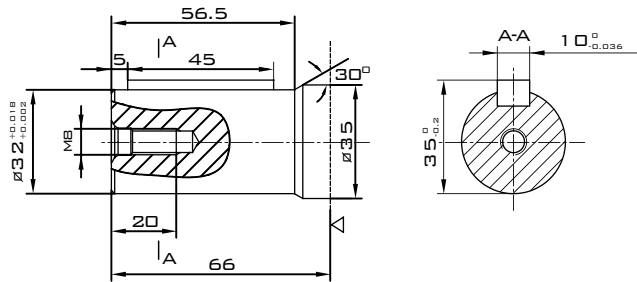

Z: $\varnothing 35$ TAPERED SHAFT, TAPER 1:10
PARALLEL KEY 6X6X30

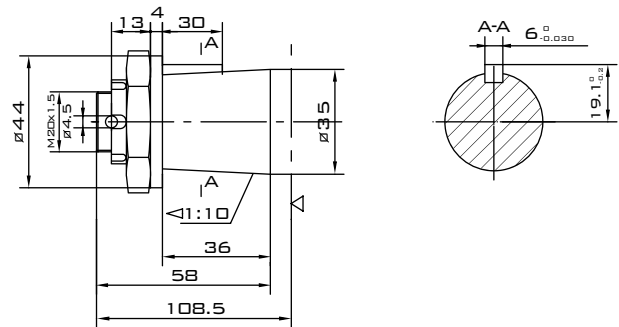

K23: $\varnothing 31.75$ INVOLVE SPLINED SHAFT
14-DP12/24 A=30°

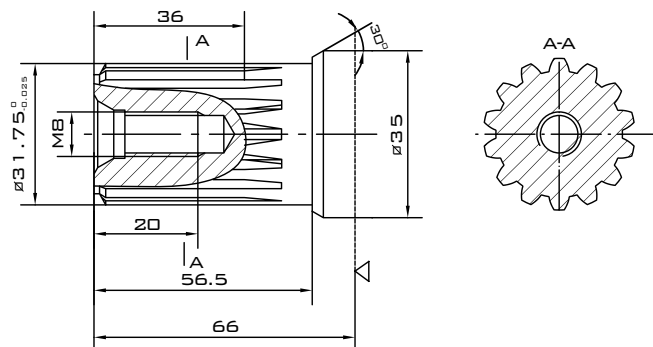

◁: MOTOR MOUNTING SURFACE

ORDER CODE

SERIES	BM3Y BM3WY	ROTATION DIRECTION	OMIT = STANDART L = OPPOSITE
DISPLACEMENT	80 100 125 160 200 250 315 400 500	SPECIAL FEATURES	OMIT = STANDART
OUTPUT	P10 = $\varnothing 32$ CYLINDRICAL Z = $\varnothing 35$ TAPERED, (ONLY FOR BM3WY SERIES) K23 = $\varnothing 31.75$ INVOLUTE SPLINED	CODE PORTS	PORTS(A,B)(DEEP) DRAIN PORT T(DEEP) Y = G1/2(15) G1/4(12)
		FLANGE	A = 4 - $\varnothing 13.5$ SQUARE FLANGE PILOT $\varnothing 82.5$